

Simplified®

Simplified, for peace of mind!

User Manual : CF-YP
Simplified Smart Cylinder



Scan for more help!

Security is just a touch away



Simplified, for peace of mind!

User Manual : CF-YP Simplified Smart Cylinder



Discover our Range of Products:
Simplified is a London-based tech company rolling out innovative IoT devices to elevate the smart home experience. Control your home with a range of smart security devices from Simplified. Whether it's a Smart Door Lock, a Camera Doorbell, Simplified put you in control of your home security.

Thank you for choosing the Simplified Slim Door Lock. Please

1. Read this manual completely before using the Simplified Slim Door Lock.
2. Alkaline Batteries are recommended.
3. Replace the battery when you notice the low-battery alarm.
4. Keep the Emergency keys outside the house.

Table of Contents:

Product Overview	1-2
What's Included	3
Specification	4
Factory reset	4
Installation	
Step 1 Resize the length according to the door thickness	5
Step 2 Tighten the Screw	5
Step 3 Install Indoor knob	6
Step 4 Installation completed	6
Step 5 Install the Batteries	7
Operation	
Setting up the Smart App	8
Bluetooth Unlock	9
Add fingerprint	10
Add passcodes	11
Passcode Management	11
Create and Send e-Keys	12
e-Key Management	12
Create admin / Programme Card, Proximity Fobs, Phone Tag Stickers	13
Unlocking Records / Pair Wireless Key Fob	14
Activate Passage Mode	15
Import data from an old Simplified lock.	15
How to turn off/on the lock sound?	15
Transfer lock to a new owner	15
WiFi Bridge Pairing / Light Status / Pair the Gateway with APP	16
Pair the Gateway with APP	17
FAQ	18
Accessories	19
Contact Us	21

For more information and support on Simplified Slim Door Lock, feel free to contact us:
support@simplified.tech

Product Overview

Adjust the Cylinder to perfectly match your door and escutcheon.

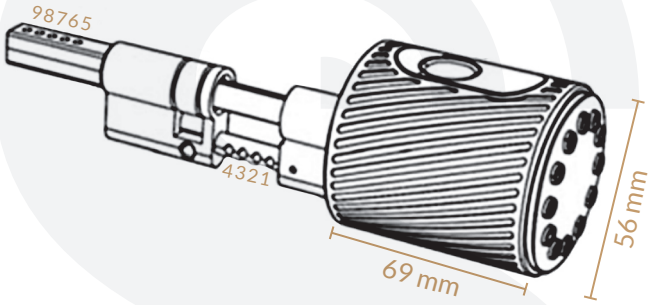

80 mm Lock core

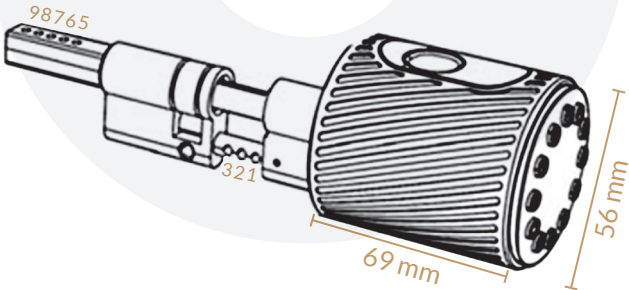

60 mm Lock core

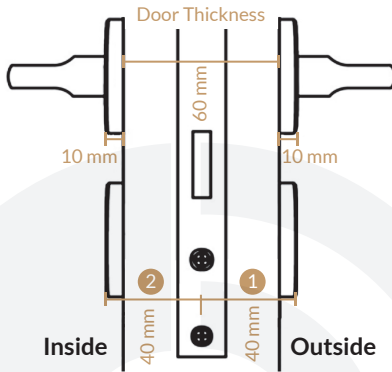

In this example, the door thickness is 60mm.
The escutcheon thickness is 10mm each.
So we need to increase the length by 10mm for each side.

For the outer part:

1. We unscrew the hex on the cylinder body
2. then secure it on the 2nd hole, extending the outer part to 10mm.

	1	Outdoor length	2	Indoor length
60 mm ~ 85mm	30 mm	1	30 mm	5
	35 mm	2	35 mm	6
	40 mm	3	40 mm	7
	45 mm	/	45 mm	8
80 mm ~ 110 mm	40 mm	1	40 mm	5
	45 mm	2	45 mm	6
	50 mm	3	50 mm	7
	55 mm	4	55 mm	8

For the inner part:

It's easier. After mounting the cylinder on the door, we can screw the inner knob on the proper hole.

In this case, it will be the number 6 that gives us the 10mm that we want.

What's Included?

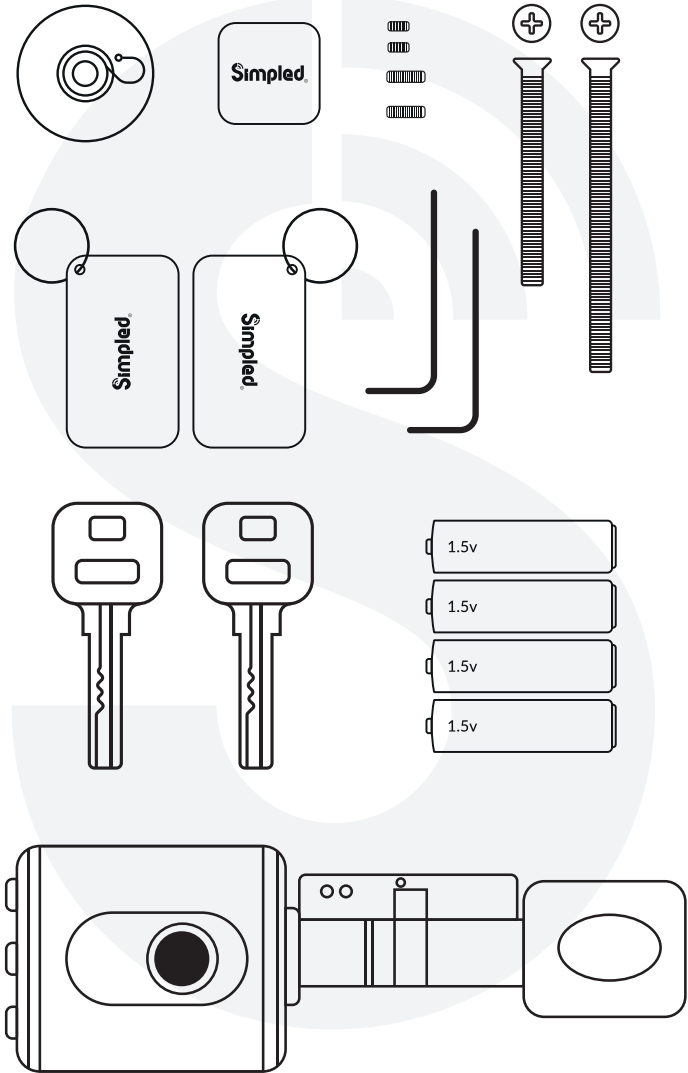

Simpled

Specifications

Model: CF-YC

Materials	Aluminum alloy
Lock Weight	1 KG
Unlocking Way	Bluetooth Fingerprint Password Proxy Fob / Stickers Emergency Key Alexa (Bridge needed) Google Home (Bridge needed)
Colour	Silver - Black
Low Battery Alarm	Less than 4.8 v
Doors Applicable	Aluminium Door Wooden Auto
Battery Voltage	6V/4 x AA Batteries
Door Thickness to Fit	60-85mm 80-110mm
Data Capacity	Fingerprint: 200 Password: 150 Fob: 200
Working Temperature	-10°C-55°C
Working Humidity	0-95%



Factory reset

Open the cover and long-press the "reset" button for 5 sec. Then key in "000#". It short beeps twice to show it is successfully reset.

Setup1 Resize the length according to the door thickness

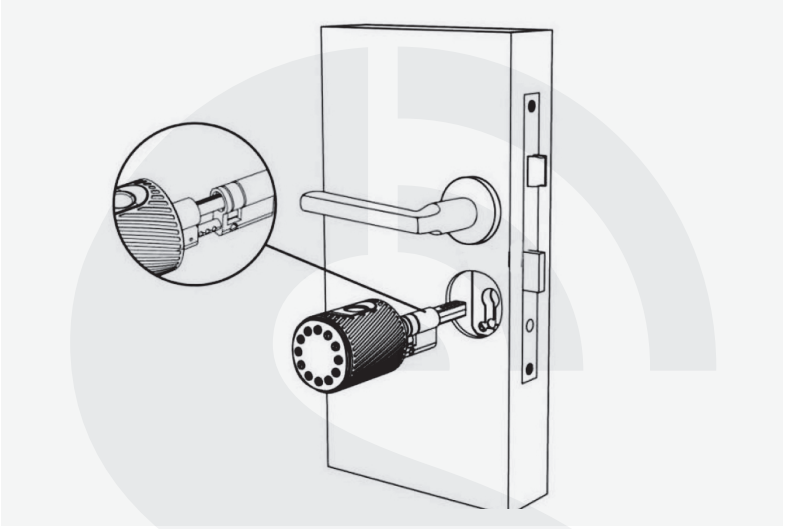

Setup2 Tighten the Screw

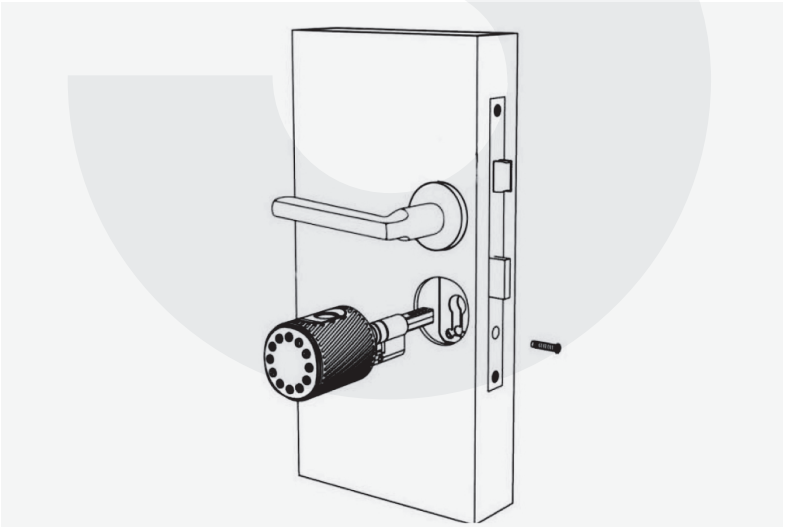

Setup3 Install Indoor knob

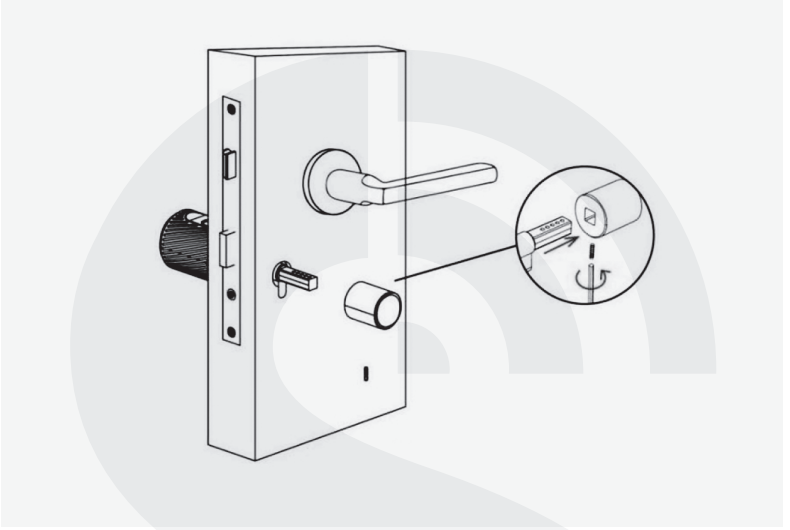

Setup4 Installation completed



Setup5 Install the Batteries



1. Insert the key and rotate counterclockwise to unlock. Remove the keypad panel. (When you open it for the first time, there's no hex screw.)

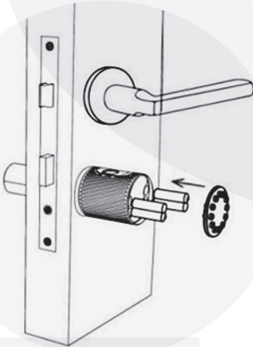

2. Alkaline batteries are highly recommended

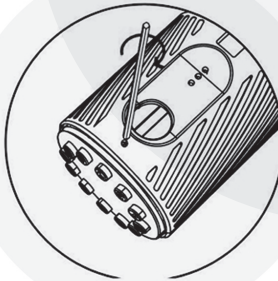

3. Take the M1.5*5mm hex Screw out of the fitting bag and tighten it clockwise.

Operation

Setting up the Smart App

1. Download the "TTlock App" from the App Store or Google Play by either
 - Scanning the QR code
 - Searching the "TTLock" app
2. Sign up for a TTlock account, and add the smart lock to the device list

Register

Email Phone

Enter your Email

Password

Confirm Password

Verification Code [Get Code](#)

Your password must have 8-20 characters, and include a minimum of two types of numbers, letters and symbols

Register

By Registering you agree to our [Privacy Policy](#)

Login Register

Phone number/Email

Password

Login

[Forgot Password?](#)



Scan for more help!

You can register an account by your email address or mobile number that is available in 200 countries around the world.

Operation

3. Activate the lock's Bluetooth by touching the Lock's keypad
4. Tap on "+ Add Lock" and select your lock type. Press on "All Locks" if you are not sure.
5. In the "Nearby Locks" list, select the appeared lock. Please make sure you are near the lock in the Bluetooth range.
6. Rename the Lock "Sweet Home, Spain Villa, London Office, ..."

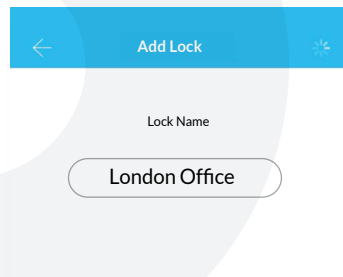
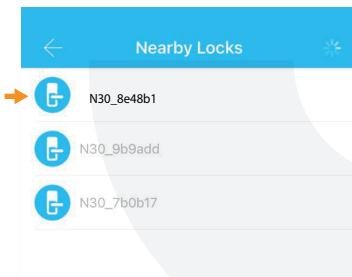
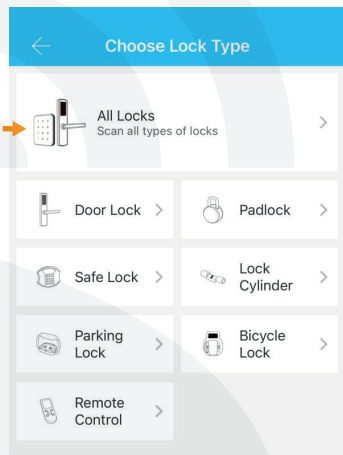
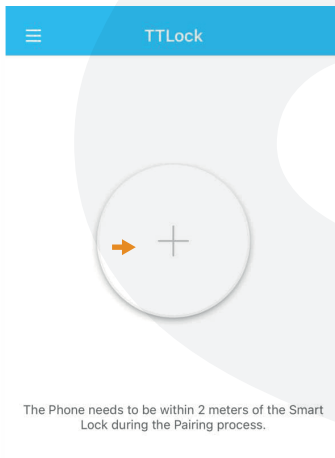

Notice: Generally, the passcode for a lock that has not yet been added is 123456

Bluetooth Unlock

Try to open the lock by tapping on the "Lock Icon". Please ensure there is no problem with Bluetooth communication, and the phone is within the 5-meter range of the Simplified Smart Lock.

Simplified

Add Fingerprints

For adding a new fingerprint,

1. Select Fingerprint from the lock screen in the app
2. Tap on the three dots
3. Select Add Fingerprint
4. Choose a name for later reference " It helps you to recognise the fingerprint in the unlocking reports".
5. Choose whether you want to create limited-time or permanent access.
6. Then start and press your fingerprint 4 times on the fingerprint sensor
7. You should see it is done successfully.
8. Test the fingerprint.

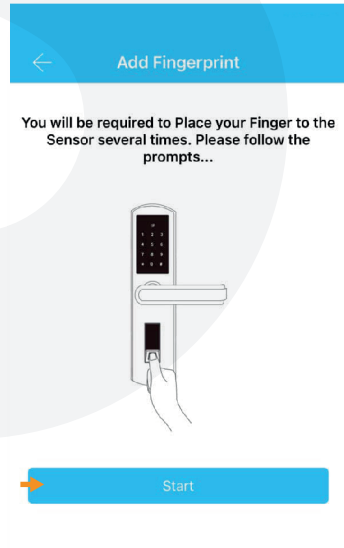
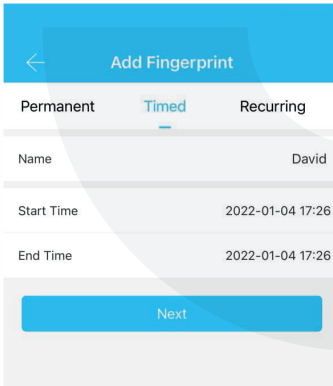
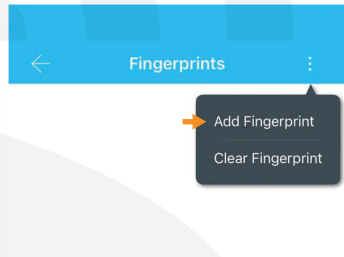
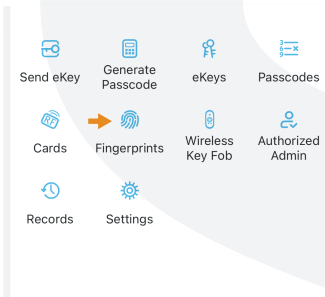

Add Passcodes

You can create different passcodes types to open the Simplified slim lock: permanent, time-limited, OTP(one-time passcode), cycle or custom. You can easily share the passcode with other users via SMS, Email, WhatsApp.

You can create, limit, share and delete a passcode without a bridge using the app when you are near the lock.

But for example, If you want to eliminate a passcode remotely, you need a Bridge. You can learn more about Bridge features in its section.

Gain access with Passcodes:

1. Touch the keypad with your palm or back of your fingers to wake up the lock.
2. Enter the generated passcode. (Before setting new passcodes, the default code is 123456#)
3. Press #.

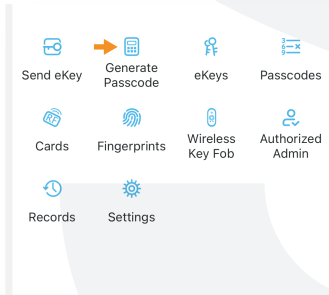

← Generate Passcode

Permanent
Timed
One-time
Erase
Custom
Recu

Permanent

Start Time 2022-01-20 04:00

End Time 2022-01-20 04:00

Name Enter a name for this passcode

Passcode 4 - 9 Digits in length

You can Configure the Customized Passcode via Bluetooth or Remotely via a Gateway.

Set Passcode

Passcode Management

Click on "Passcodes". In this section, the Admin user can

1. Change, delete or reset passcodes.
2. Review the unlock records of passcodes.

Create and Send e-Keys

By selecting the “Send eKey” as shown in the figure, you can create and share an electronic key with your friends, family, maid, dog walker or your AirBnB guests. For using the eKey, they need to download and sign up for a new account. This will also help you find out about the time they opened the lock. E-Keys are also available in different types: Permanent, Time-Limited, One-time and recurring.

You can authorise a user as Admin in the Authorised Admin section

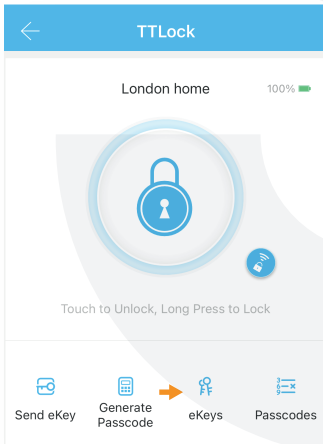
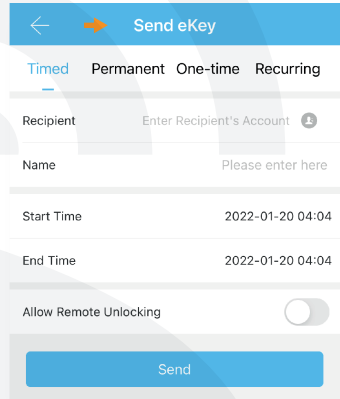
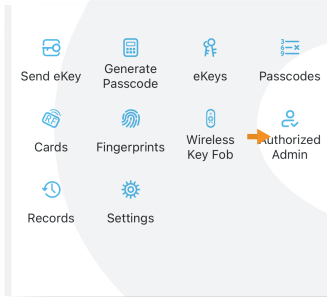

e-Key Management

Click on eKeys. In this section, the Admin user can

1. reset or delete eKeys.
2. review the access records.

Create Admin

With this feature, you can assign a new timed/ permanent admin to have the same level of access to the lock.

For example, your receptionist or even your guest will be able to add new users and even register their own fingerprint on the smart lock, up to the time their users are valid.

Programme Card, Proximity Fobs, Phone Tag Stickers:

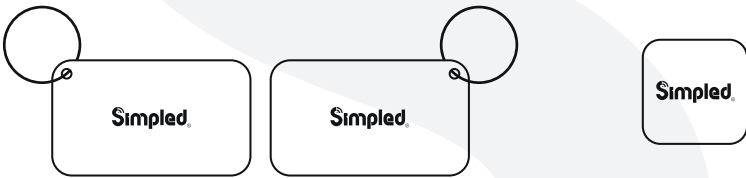

Before a proxy fob or sticker can open the lock, it is required to be programmed first. Fobs/Stickers can also be Permanent or Limited by time.

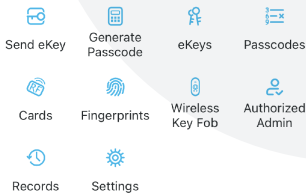

Unlocking Records

Tap on "records". In this part, you can review all the unlock records

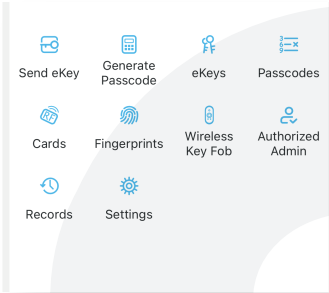

Pair Wireless Key Fob (Bluetooth Remote Controller)

1. Tap on "Wireless Key Fob".
2. Add Key Fob
3. Use Permanent/Timed/Recurring Tab.
4. Long Press the Locking Key on the Remote controller for 5 seconds.
5. Tap "Next" when the light flashes quickly.



←
Add Key Fob

Long press the locking key for 5 seconds

Indicator Light

Click next when the light flashes quickly

Next

Activate Passage Mode

1. Choose the lock
2. Tap on "Settings"
3. Select "Passage Mode"
4. Turn on this mode and press Save

Note: To activate the passage mode, you need to unlock it once with the app!

When passage mode is activated, you can long-press # to force-lock the Simplified lock! It's the same when the auto-lock feature is off; you can long-press # to lock the door.

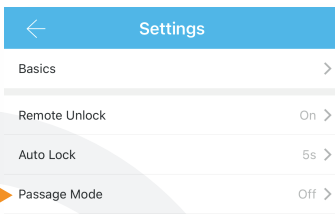

Import data from an old Simplified lock.

To transfer data from an old Simplified lock to a new one you can follow these steps:

1. Choose the new lock on the app.
2. Tap on "Settings"
3. Select "Import from another lock"
4. Choose your old lock from the list.

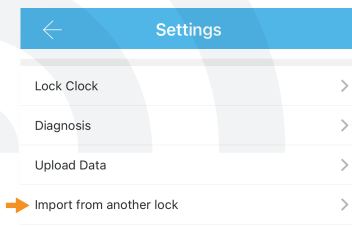

How to turn off/on the lock sound?

1. Open the app.
2. Tap on the lock.
3. Choose "Settings".
4. Disable/Enable the Lock sound.

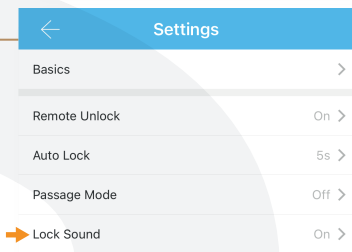

Transfer lock to a new owner

1. Open the app
 2. Tap on the ☰ (Top Left)
 3. Select "Settings"
 4. Tap on "Transfer Lock(s)"
 5. Select the lock(s) and press Next
 6. Enter the new owner Account, and press Next.
- Notice: The selected lock(s) will be permanently transferred.

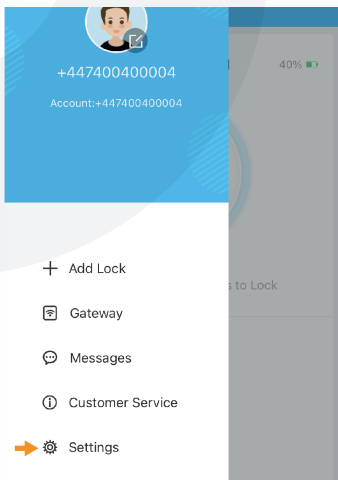
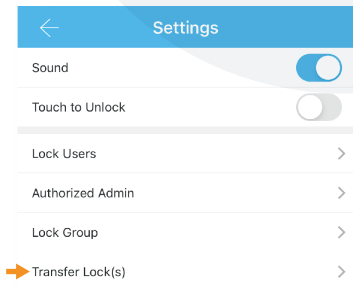

WiFi Bridge Pairing

The Simplified Smart WiFi Bridge is a bridge between Simplified Smart locks and WiFi. With the Gateway, you can

- open your lock from anywhere
- remotely read the lock operation records, including, fingerprint, passcodes
- calibrate the lock clock remotely
- remotely delete and modify passcodes
- use the Simplified lock with your Alexa
- use the Simplified lock with your Google home

Light Status



When the WiFi Bridge is powered on:

- Light Flashes alternately in Red and Blue: Stand-by mode, ready for pairing
- Blue light: Working mode
- Red Light: Network failure

Pair the Gateway with APP

1 Activate the APP



2 Pres "☰"



3 Select (Gateway)



4 Select (G2)

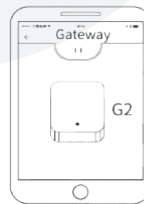

Pair the Gateway with APP

- 5 Plug in the Gateway and power it on, while the light Flashes alternately in red and blue

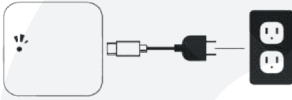

- 6 Press “+” sign



- 7 Add (Gateway)



- 8 Select the network and fill in the password



- 9 Add complete

Notice: If times out, please turn off and on, and try it again.

After pairing the WiFi Bridge, please turn on "Remote Unlock" on the TTlock settings.



Scan for more comprehensive TTlock app manual.

FAQ

1. How can I read the operation records?

1. Open the app
 2. Select your lock
 3. Select "Records"
-

2. I cannot change the passcode. It says Operation failed.

First, Ensure your smartphone is within 2 meters of the cylinder when setting the passcode. If it is, turn off your smartphone's Bluetooth for 10 seconds and turn it on again.

3. After installation, I touched the keypad, but there was no response. What is the reason?

- A) Check if the battery is placed correctly and if it has enough power. New Alkaline Batteries are recommended.
 - B) Check if the battery cover is fitted properly.
-

4. I had a problem registering my fingerprint.

Check if your fingerprints are clean without any dirt or wear. Clean the sensor with a soft cloth making sure there's no oil, stains, etc.

5. What happens if you enter the wrong password into the lock too many times?

After five failed attempts to enter your passcode, your lock will be disabled for 5 minutes. You can try other unlocking methods.

Accessories



More accessories?
SCAN HERE

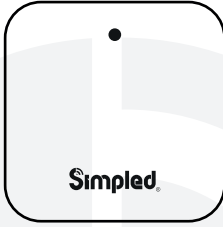

WiFi Bridge

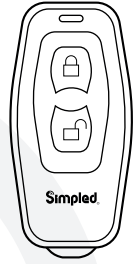

Bluetooth
Remote Controller

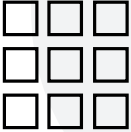

Another Smart lock
for other doors

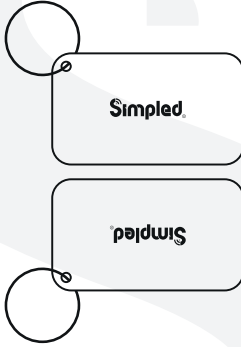

Proxy Fobs
Contactless Keys

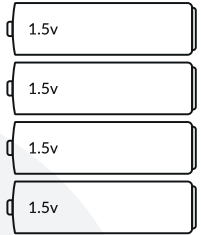

Lithium Battery 1.5v



Smart lock for
a friend or family



Phone Tag (Sticker)
Contactless Key

Note:

A series of horizontal dotted lines for writing, overlaid with a large, faint, light-gray watermark of the letter 'S'.

Contact us:



SimpledTech



simplified.tech



simplified.tech



simplified-tech

Note:

1. We provide you with a two-year warranty from the date of purchase.
2. This warranty service is valid for customers in any country in the world.
3. For more help please scan the QR code, or contact us:
support@simplified.tech



Scan for more help!

**WOW!**

If you are happy with your purchase, please feel free to share your new-found happiness.

1. Go to Amazon > Your Account > Your Orders.
2. Locate your Simpled purchases.
3. Click " Write a product review" .

OR**MEH.**

If you have any question, concerns or complaints about your Simpled purchase, please contact us at:

Email: support@simplified.tech

We will get back to you within 24 hours, Promise.